

M line



General Characteristics

M line is a complete series of microprocessor based relays suitable for protection of high and medium voltage systems; it offers a unique combination of performances, functionalities, innovation and reliability. The line is completed by a number of communication and control modules giving a good level of modularity.

Measurements

- Real Time Measurements
- Maximum Demand and Inrush Recording
- Trip Recording (last 5 trips with date & time)

Control

- 5 Output Relays (programmable)
- 3 Digital Inputs
- Time tagged event recording
- Blocking Outputs and Blocking Input for pilot wire selectivity coordination

Communications

- 1 RS485 Serial communication port on rear side
- Modbus RTU Communication Protocols

Technical Characteristics

- Complete autodiagnostic program
- 8 Digit alphanumerical Display
- 8 Leds for signalization

Mounting

- 2 Module boxes
- IP44 protection case (on request IP54)
- Totally draw-out execution

Software

- MCom Program interface for device management

Relays Type

IM30-AB	Three-phase Overcurrent and Earth Fault - Dual Setting : 50/51, 50N/51N, 51BF
IM30-AP	Three-phase Overcurrent and Earth Fault: 50/51, 50N/51N, 51BF
IM30-C	Capacitor Overload, Earth Fault And Unbalance Protection: 50/51, 50N/51N, 46N, 37, 51BF
IM30-D	Three-phase Overcurrent + Directional Earth Fault: 50/51, 50N/51N/67N, 59Uo, I't, 51BF
M-ARM513	Multishot Programmable Single/Three Phase Autoreclose: 79
SCM21	Three Inputs Synchrocheck: 25, 27/59, 81.
MM30	Motor Protection: 12/14, 37, 46, 47, 48, 49, 50/51, 51LR, 64, 66
MM30-D	Motor Protection With Directional Earth Fault: 12/14, 37, 46, 47, 48, 49, 50/51, 51LR, 64N, 66
MM30-W	Motor Protection Relay With Voltage & Power Control: 12/14, 27/59, 37, 46, 47, 48, 49, 50/51, 51LR, 55, 64, 66, 81
IM30-T	Three-phase Thermal + Overcurrent + Earth Fault: 46, 49, 50/51, 50N/51N, 51BF, I't
MD32-T	Percentage Biased Transformer Differential: 87, 87N
MD33-T	Percentage Biased Differential Relay For 3-winding Transformers: 87, 50/51
MTR33	Transformer On-load Tap-Changer Control: 27, 59, 37, 50/51, 90
IM30-G	Multifunction Generator Protection: 32, 40, 46, 50/51, 51BF, 64S
IM30-B00	Earth Fault Relay - Dual Setting: 50N/51N, 51BF
IM30-DR	Three-phase Overcurrent with Directional Earth Fault + Autoreclosing: 50/51, 50N/51N/67N, 46, 79, 51BF
MG30	Generator Protection & Management: 21, 24, 27/59, 32, 37, 40, 46, 49, 50/27, 50V/51V, 51BF, 60FL, 64S, 81
MD32-G	Percentage Biased Generator Differential Relay: 50/51, 87N or 64S, F87, 51BF
SPM21	Generator Synchronizing Relay: 25, 27/59/81, 90
M-LIB3	Modular Low-Impedance Bus-bar Protection: 87B
M-HIB3	High Impedance Biased Differential Relay: 87, 51BF
M-HIV3	Three Phase High Impedance Busbar Differential Relay With Supervision of CT Secondary Circuits: 87B, 59S
MFP	Pilot Wire Differential Protection Relay for Cables & Lines: 87/85, 50/51, 51BF
UM30-A	Three-phase Voltage, Frequency & Zero Sequence Voltage with Vector Shift Detection: 24, 27d/59d, 47, 59, 59Uo, 81
UFD34	Three-phase Digital 4-stage Frequency Relay With Df/dt & Dv/dt Control: 27/59, 81, df/dt, dv/dt
MU30	Multifunction Three-phase Measuring Unit
MW33	Power Management Relay: 27/59, 81, 32
MX7-5	Programmable Interface & Control Module: 7 Digital Inputs & 5 Output Relays
MX14-5	Programmable Interface & Control Module: 14 Digital Inputs & 5 Output Relays



Electronic

Relays: M line

Wiring Diagram

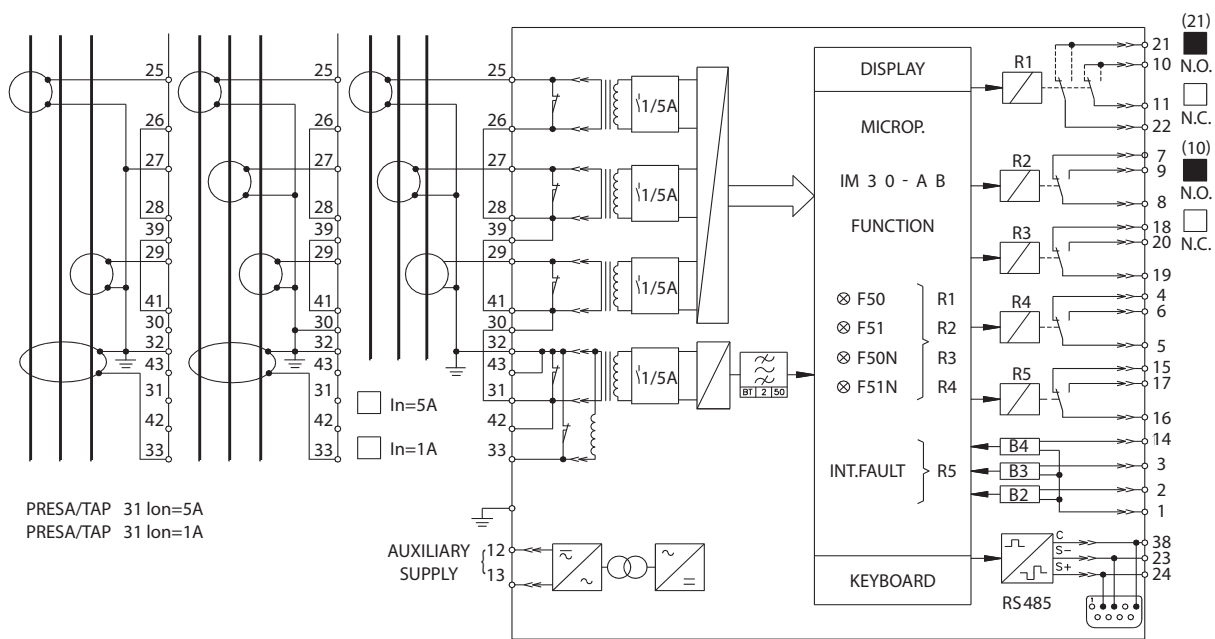

Overall Dimensions (mm)

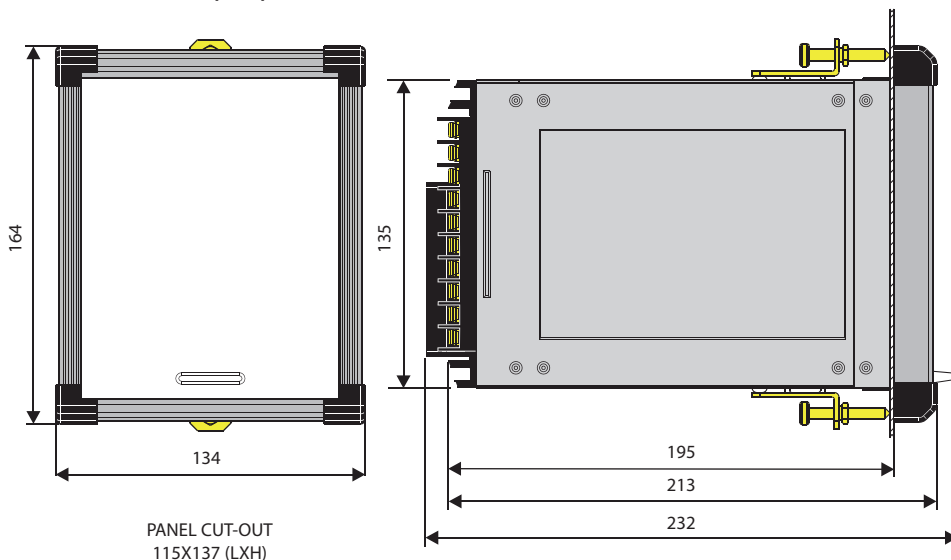

KNORR-BREMSE



Microelettrica Scientifica

Microelettrica Scientifica S.p.A. Via Alberelle, 56/58 20089 Rozzano - Italy
Tel.: +39 02 575731 Fax: +39 02 57510940 - sales.relays@microelettrica.com
www.microelettrica.com